

SPECIFICATION
 Current:1.5A Max.
 Voltage:30V Max.
 Withstanding Voltage:500V AC
 Contact Resistance:30 Milliohms Max.
 Insulation Resistance:1000 Megaohms Min.
 Temperature Range:-55°C~+85°C
 Mating Force:35N Max.
 Withdrawal Force:10N Min.
 Durability:1500 Cycles Min.
 Contact:Phosphor Bronze
 Selective Gold 1u" Plated Over Nickel
 Insulator:PBT+30%G.F.(UL94V-0),White
 Shell:Brass,Nickel Plated
 Back Shell:SPCC,Nickel Plated
 RoHS Compliant

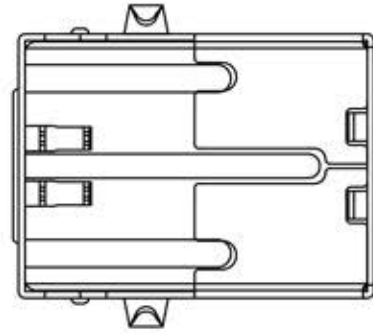
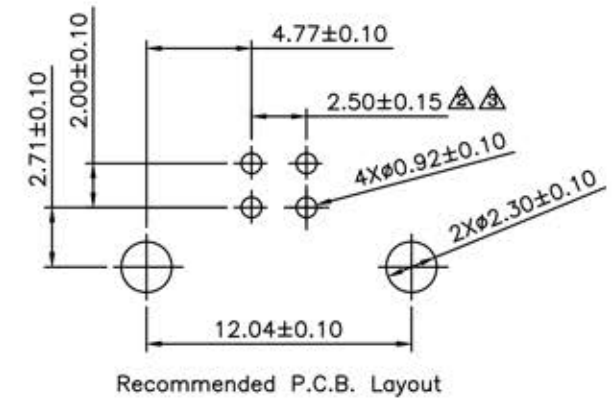

پارت هاب PART HUP
 از بازار، آنلاین بخرید
 پیازها PH

DRAWING No.		APPROVED BY		UNLESS OTHERWISE SPECIFIED TOLERANCES ARE					
15765		MEI		.X ±0.38 .X' ±2'		A3		Modify Data	
		CHECKED BY		.XX ±0.25 .XX' ±1'		A2		Modify Data	
		DRAWING BY		.XXX ±0.13 .XXX' ±0.5'		A1		Modify Data	
SCALE		REV.		UNIT		A0		NEW RELEASE	
NONE		A3		mm		NO.		REVISIONS	
						REV.		DATE	
						9		CHK	
						10		DATE	